

LONG TERM PERFORMANCE AND DURABILITY OF EPS AS A LIGHTWEIGHT FILLING MATERIAL

Tor Erik Frydenlund¹ and Roald Aabøe²

ABSTRACT

Some 30 years of experience with Expanded Polystyrene (EPS) as a lightweight filling material in Norway has brought about both a wider use on a global scale and the introduction of a number of different design applications. In addition to reduced vertical loads, advantages from using EPS may also include reduced horizontal loads, simplified designs, foundations placed directly on EPS blocks and increased speed and ease of performing construction activities. This document describes practical experiences in Norway with long term performance and durability of EPS as a fill material based on observations and recorded data from monitoring programmes.

¹ Chief Engineer, Soil Mechanics Division, Road Technology Department (NRRL), Directorate of Public Roads, Norwegian Public Roads Administration, Gaustadalleen 25, P.O. Box 8142 Dep, N-0033 Oslo

² Senior Engineer, Soil Mechanics Division, Road Technology Department (NRRL), Directorate of Public Roads Norwegian Public Roads Administration, Gaustadalleen 25, P.O. Box 8142 Dep, N-0033 Oslo

INTRODUCTION

In Norway the Public Roads Administration has a long tradition in applying various types of lightweight filling materials for road construction purposes. During the last 50 years wooden materials like sawdust and bark residue from the timber industry have been applied for such purposes. Also waste materials from the production of cellular concrete blocks and Leca (Light Expanded Clay Aggregate) have been widely used. In this connection also monitoring programmes were initiated in order to investigate the long term performance of these materials. Presently a new option is being investigated involving the use of granulated foamed glass produced by re-circulating waste glass.

When a major research project on frost action in soils was carried out in Norway during the period 1965 to 1973 this included the investigation of various insulation materials for frost protection of roads like 50 to 100 mm thick boards of foamed glass, extruded polystyrene (XPS) and expanded polystyrene (EPS). In this connection also fatigue tests were performed. It was then concluded that EPS material could sustain the repetitive stresses occurring in a road structure and the idea of applying EPS in greater layer thickness than boards emerged.

In 1972 the Norwegian Public Roads Authorities adopted the use of EPS as a super light filling material in road embankments. The first project involved the successful reconstruction of road fills adjacent to a bridge founded on piles to firm ground. Prior to reconstruction the fills, resting on a 3 m thick layer of peat above 10 m of soft marine clay, experienced a settlement rate of more than 200 mm per year. By replacing 1 m of ordinary fill material with two layers of EPS blocks, each layer with 0,5 m thickness, the settlements were successfully halted. When placed the EPS blocks had a density nearly 100 times lighter than the replaced materials.

Since then authorities in several countries have also found the method advantageous for building roads across soft ground and for other construction purposes where low loads are essential. In addition to reduced vertical loads, advantages from using EPS may also include reduced horizontal loads, simplified designs, foundations on EPS and increased speed and ease of performing construction activities. The method is now in common use in several countries in Europe, Asia and North America. At present more than 350 road projects involving EPS fills have been completed in Norway with a volume of totalling some 500,000 m³ of EPS blocks.

EPS does of course not represent the only solution to bearing capacity and settlement problems. Other lightweight filling materials should also be considered together with other alternatives such as replacement or displacement of the weak soil or soil improvement, piled foundations etc. Availability and cost are important factors in this connection, but in many cases the use of EPS will prove advantageous and in some cases represents the only practical solution. In a book published (1997) by PIARC, the World Road Association, lightweight filling materials in common use are presented together with case histories.

MONITORING PROGRAMME

Expanded polystyrene is a very stable compound chemically and no material decay should be expected when placed in the ground and protected according to the present design guidelines. Still, since the first road insulation project with EPS was performed in 1965 and the first EPS light weight embankment was constructed in 1972, EPS fills have also been monitored for long term performance along the lines followed for other lightweight filling materials used in road construction in Norway.



Figure 1. An EPS embankment for a city tramline in Oslo with vertical walls as an alternative to a bridge.

The monitoring programme has focused on the following material qualities:

- Material behaviour
 - *Compressive strength*
 - *Water absorption*
 - *Decay*
- Deformation
 - *Total fill deformation and deformation in EPS layers*
 - *Creep effects*
- Stress distribution
- Reduced lateral pressure
- Bearing capacity

TESTING FREQUENCIES

Since 1972, several tests have been carried out in order to monitor possible material changes. In this connection test samples have been retrieved from existing fills to be checked for possible changes in strength and unit density. Also variations in water absorption for blocks placed in drained, submerged or semi-submerged positions have been observed. In order to determine the stress distribution within blocks and fills both laboratory and field tests have been performed. Finally load creep effects have been observed both in the laboratory and on existing fills.

In Norway test samples have been retrieved from a total of five fills.



Figure 2. Excavation of the first EPS embankment at Flom bridge

The testing frequency is shown in table 1.

Fill location	Constructed	Test samples retrieved			
	Year	No. of years after construction			
National road 159 Flom bridges	1972 / 73	0	7	12	24
National road 154 Solbotmoan	1975	4	9	21	
County road 91 Lenken	1978	6			
County road 26 Langhus	1977	7			
National road 610 Sande - Osen	1982	9			

Table 1 Testing frequencies of EPS embankments.

MATERIAL BEHAVIOUR

Material strength

According to Norwegian specifications the design compressive strength of EPS blocks have been set to be at least $\sigma = 100$ kPa when not otherwise specified. In actual practice a shipment of blocks may be accepted if the average strength of tested blocks is $\sigma \geq 100$ kPa. The average value for test specimens from one block (6 tests) should be $\sigma \geq 90$ kPa and no single tests should show values $\sigma < 80$ kPa.

One major indicator of possible deterioration of blocks with time would be a decrease in the material strength. The strength tests performed on retrieved samples from fills having been in the ground for up to 24 years are shown in figure 4. as a function of dry unit density and compressive strength. Bearing in mind the criteria mentioned above for accepting blocks to be placed in a fill, all test results give values of compressive strength above $\sigma = 100$ kPa except for one test.



Figure 3. Excavation of a 24 years old EPS block from the first EPS embankment at Flom bridge

This one test was performed on samples taken from the first fill shortly after it was completed in 1972, and is more an indication of variations in material quality of EPS with the production process used at that time. Still the observed value is within the accepted statistical variations in material strength.

From figure 4 it may also be observed that the majority of tests show values of compressive strength in relation to unit density above that of a normal quality material. Although it is of course impossible to make exact comparisons between material strength at the time of construction and some time afterwards since tests cannot be performed on the same specimen twice, the results indicate clearly that there are no signs of material deterioration over the total time span of 24 years. If a change tendency is to be noted, this would go towards a

slight increase in material strength. If this is the case, such an increase could be explained by a continued chemical reaction leading to material hardening during the first few weeks after production. There is also a tendency that the material strength is slightly higher in the middle of the block than towards the outer sides. Furthermore there is no

sign of variation in material strength whether the retrieved specimens are tested wet or dry. This indicates that water pickup over years in the ground will not affect material strength.

UNIT DENSITY

The only change in design rules that have been introduced in Norway since the first fill in 1972 is that the design unit weight for EPS blocks placed in a drained position is reduced from $\gamma = 1.0 \text{ kN/m}^3$ ($\rho = 100 \text{ kg/m}^3$) to $\gamma = 0.5 \text{ kN/m}^3$ ($\rho = 50 \text{ kg/m}^3$) when stability and settlement calculations are performed. For blocks placed in a submerged or semi-submerged position the value of $\gamma = 1.0 \text{ kN/m}^3$ ($\rho = 100 \text{ kg/m}^3$) is maintained. The change mentioned above is based on tests data from existing fills.

EPS placed in the ground will absorb water in two ways. One is by water entering possible voids between spheres due to water pressure or capillary rise. Since water vapour may diffuse through the polystyrene when there is a

temperature gradient, the water vapour will condense in the spheres if there is a drop in temperature below the dew point. However, in an EPS block of 500 mm thickness or an EPS fill of greater thickness the temperature difference over the block or fill will be very small. Possible water absorption due to water vapour diffusion is therefore expected to be small.

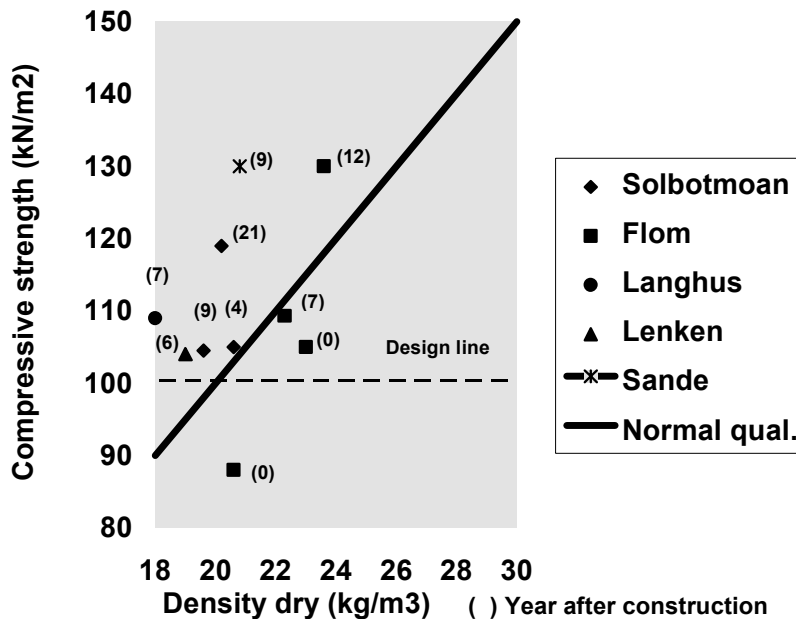

Figure 4. Compressive strength on retrieved samples from EPS fills

Water absorption due to water pressure or capillary rise depends on unit density and how well the spheres are welded together. A number of tests, mainly on small samples in laboratories, have been performed in several countries in order to study water absorption effects.

Both the quality of these tests and the results vary somewhat. Tests performed on samples retrieved from existing fills in Norway are in agreement with some of the laboratory tests.

Tests performed on samples retrieved from three EPS fills placed in a drained position, i.e. blocks are located above the highest groundwater or flood level, all show water contents below 1 % by volume after more than 20 years in the ground (fig. 5).

Furthermore there is hardly any change in the water content with time. Samples retrieved from the outer parts of blocks facing the surrounding soil, may have a higher water content as may be seen from figure 6. But only 500 mm further into the block the water content is again below 1 % by volume. So the average density of drained fills therefore has values of $\rho < 30 \text{ kg/m}^3$. This is well below the specified design value for such fills.

In blocks, which are periodically submerged, water contents of up to 4 % by volume have been measured. In permanently submerged blocks measured water contents have reached values close to 10 % by volume with some increase over the years fig. 7. Further increases above 10 % by volume are, however, not to be expected. For submerged fills the average density is therefore of the order of $\rho = 90 - 95 \text{ kg/m}^3$ after some 20 years in the ground. The water content decreases rapidly above the water table and show values for drained conditions only some 200 mm above the highest water level.

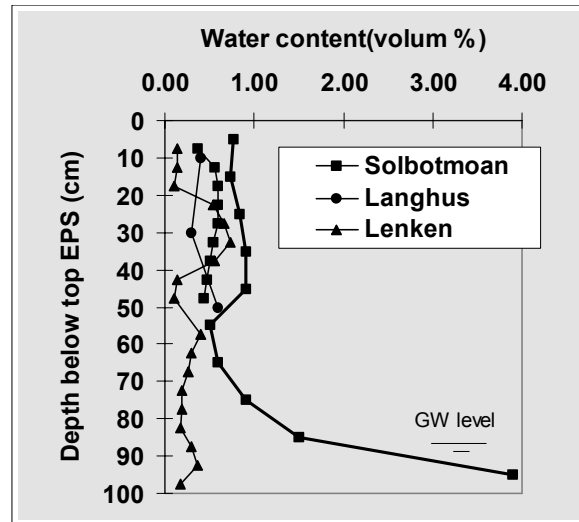

Figure 5. Typical drained situation from 3 EPS fills

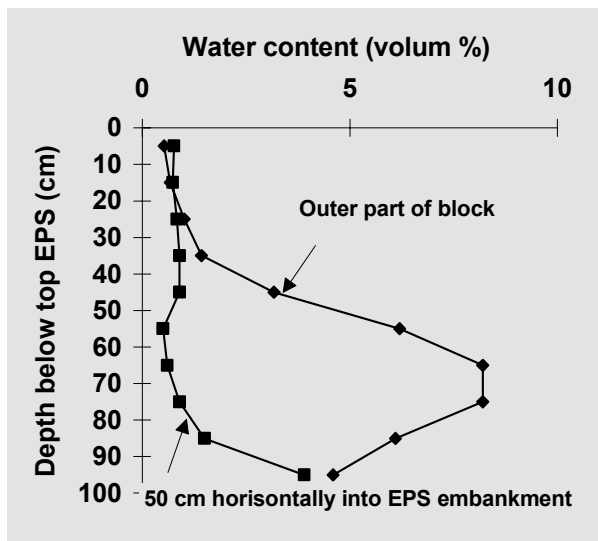

Figure 6. Horizontal gradient of water in EPS.

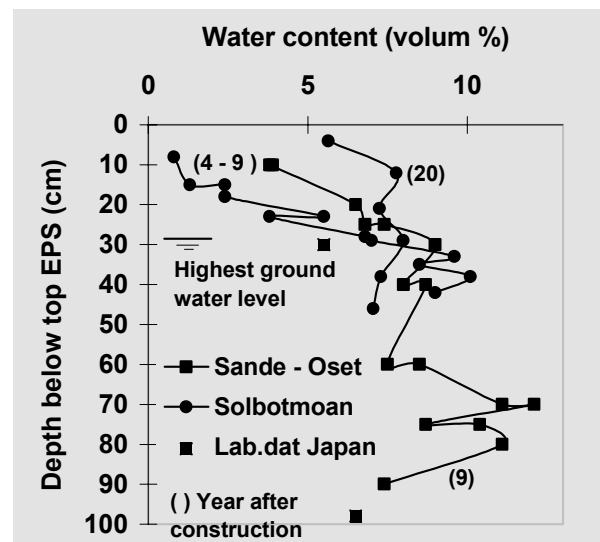

Figure 7. Typical water content in submerged EPS blocks

DEFORMATION AND CREEP EFFECTS IN EPS STRUCTURES

Both full scale and laboratory tests have been performed related to material creep and stress distribution in the material. In general only about 30 % of the material strength is utilised for supporting dead loads, i.e. $q_{dw} < 30$ kPa for normal strength blocks ($\sigma = 100$ kPa). In some special cases higher stress related to dead loads have been used.



Figure 8. EPS test fill at the Norwegian Road Research Laboratory (now the Road Technology Department).

In a laboratory test at the Norwegian Road Research Laboratory (now the Road Technology Department) a test fill of height 2 m with normal size blocks and a compressive strength $\sigma = 100$ kPa has been loaded to a value of $q_{dw} = 52.5$ kPa and the resulting deformations observed over a period of 3 years (figure 8). The results are shown in fig. 9 together with calculated deformations to be expected according to the theories introduced by Magnan & Serratrice.

As may be seen the observed deformations are only about half of the calculated values and creep deformations with time are also much smaller.

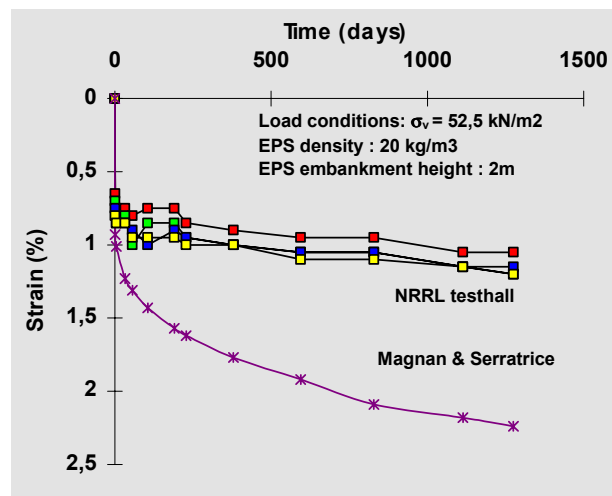

Figure 9. Deformation / creep in the test fill

Full scale test at Løkkeberg bridge founded on two EPS embankments. Long term monitoring of deformation, creep and stress distribution.

The Løkkeberg bridge is a single lane Acrow steel bridge with a single span of 36,8 m crossing road E6 close to the Swedish border. The bridge was built in 1989 in order to temporary (3 - 5 years) improve traffic safety until the completion of a new motorway between Norway and Sweden.

Due to low bearing capacity and expected large settlements, light weight fill materials (EPS) were considered in the embankments adjoining the bridge. The project provided an opportunity to place the bridge foundation directly on top of the EPS fills (height 4,5 and 5m) on both sides as an alternative to placing the bridge abutment on piled foundations. Since the bridge was a temporary solution and possible deformations could be adjusted during the period of operation, it was decided to carry out the project as a full scale test.



Figure 10. Construction of one abutment on the EPS embankments at Løkkeberg bridge.

Three different qualities of EPS material strength have been used with design strengths of $\sigma = 240$ kPa in the upper layer directly below the bridge abutment, $\sigma = 180$ kPa in the remaining layers halfway down the fill and $\sigma = 100$ kPa in the bottom half. In the upper layer only 25 % of the material strength has been utilised while in the bottom layer the corresponding figure is 60%. Construction details are shown in longitudinal profiles in figures 11 and 12.

The bridge is today still in operation 12 years after completion. No signs of cracks or uneven deformation

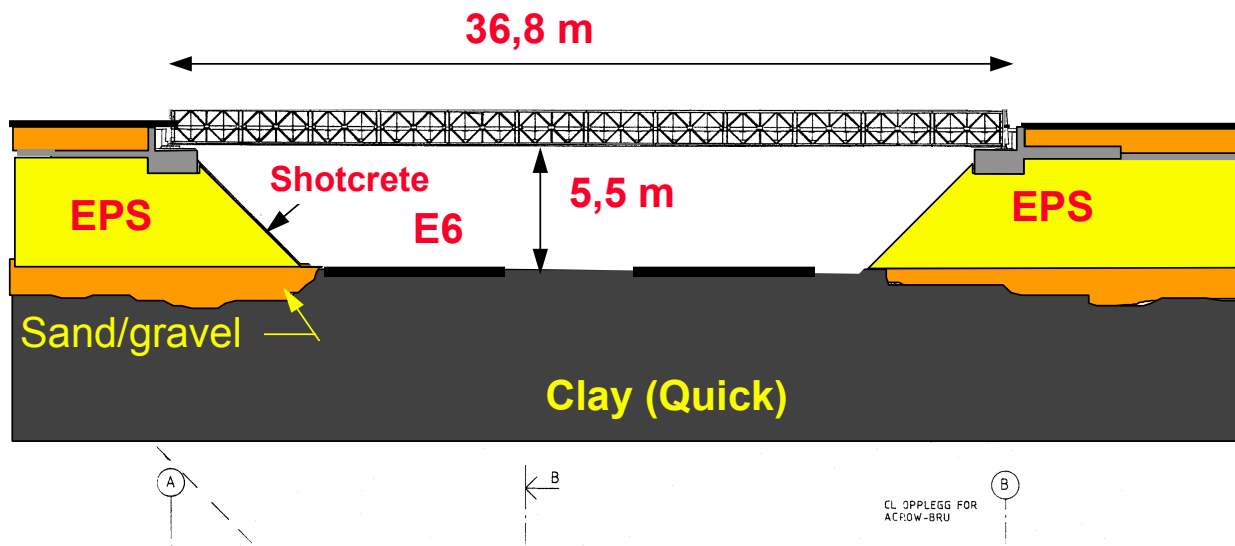

have been observed. The bridge support has been lifted 30 cm on one side due to subsoil settlements in accordance with the theoretical calculation.

Løkkeberg bridge has provided a good opportunity for monitoring long time performance such as creep and stress distribution of an EPS embankment.

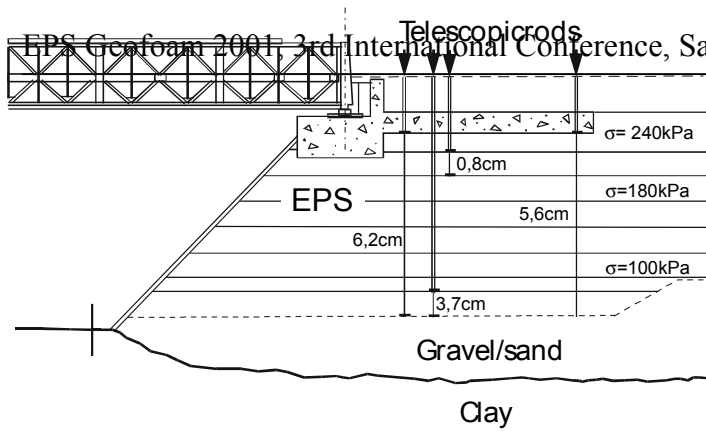

After 12 years in service measurements show only small deformations 6 cm (1,3 % of the EPS height) in the EPS embankment. Most of the deformation occurred during the construction period and only minor creep effects have been measured. Creep deformations as an average and creep deformations for the lowest EPS layer (6,5 % of the layer thickness) are shown in fig. 13 for a period of 10 years.

Figure 12. Deformations in EPS embankment at Løkkeberg.

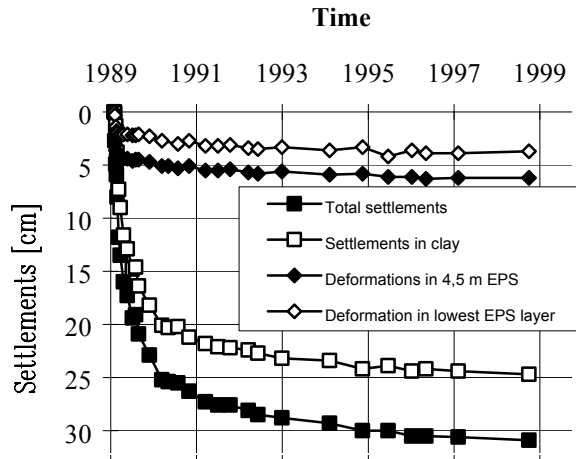

Observed deformations after 10 years in operation are plotted in fig. 14 together with data from the laboratory test and theoretical values according to Magnan & Serratrice calculated for various stress levels

The figure clearly shows that the average deformation at the Løkkeberg bridge is small and slightly over 1 % of the total fill height. Also observed creep effects are almost negligible for the total fill although deformations in the bottom block layer was 4 % initially and later creep effects amount to further 2.5 %. Creep deformations in the bottom layer correspond with the theoretical values the first 5 years but has later slowed down to almost zero.

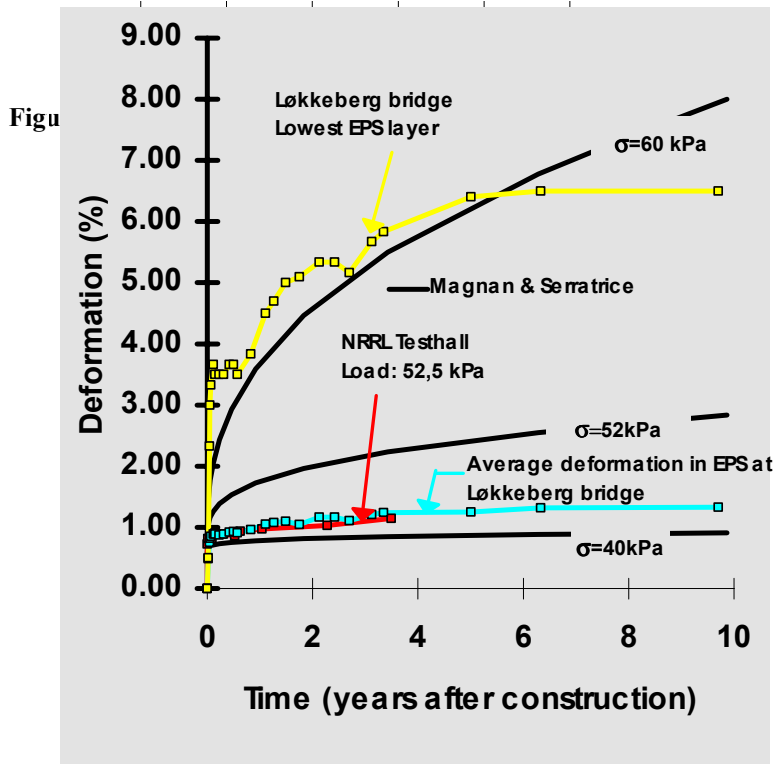

Two similar structures, a 3 span bridge at Hjelmungen and a 3 span pedestrian bridge has been built in 1994 and 1995 with abutments founded on EPS fills. Observations from these bridges correspond with the measurements at Løkkeberg and shows that this can be a promising method for supporting bridge abutments.

Figure 14. Creep deformations in EPS.

STRESS DISTRIBUTION

In order to observe the stress distribution in the EPS material below the bridge abutment at Løkkeberg bridge during construction and on a long term basis, 10 hydraulic earth pressure cells have been placed in different levels in the fill including 3 cells in the sand layer below the EPS fill. In fig. 15 the measured stress level after 10 years in

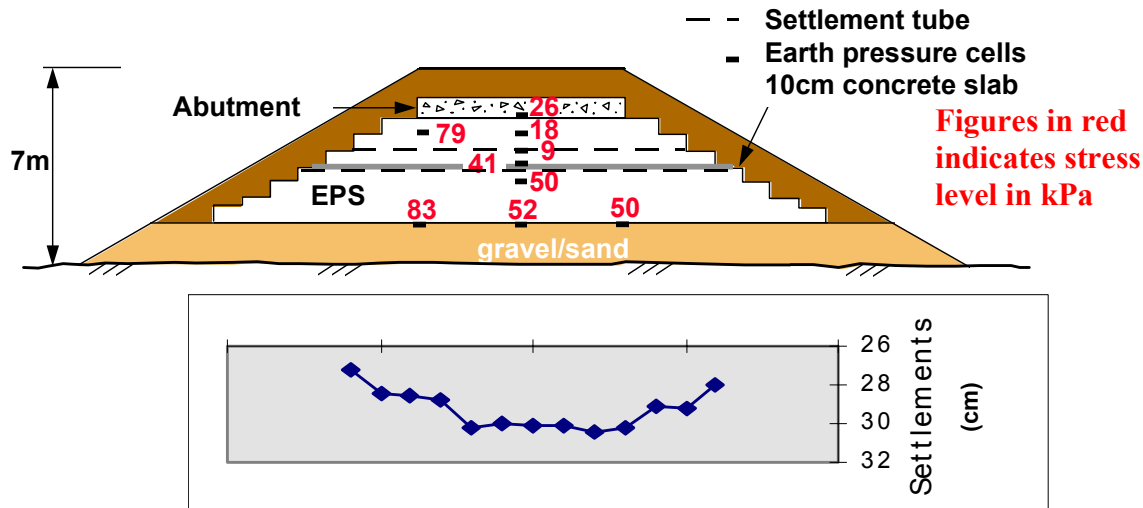

Figure 15. Løkkeberg bridge. Observed stress distribution and settlements in the cross section after 10 years in operation.

service is indicated with red figures.

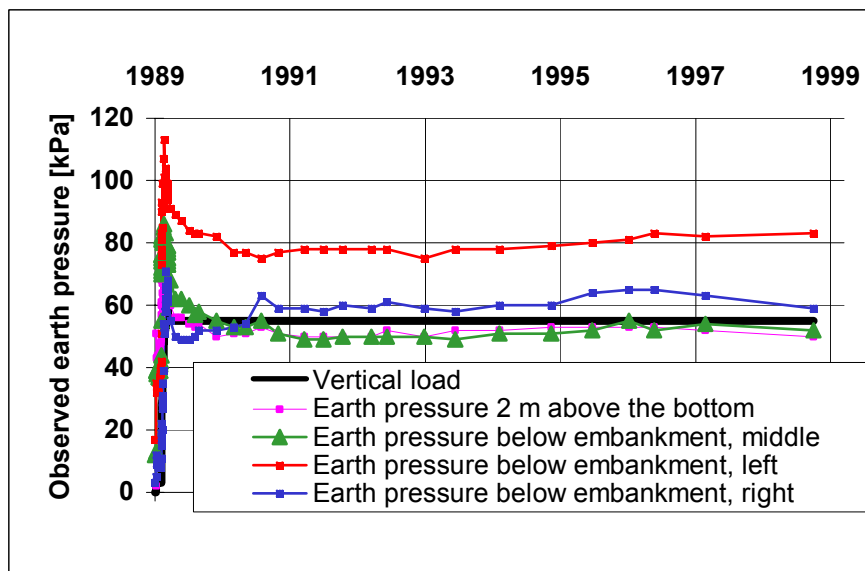

Figure 16. Long term measurements of earth pressure at Løkkeberg bridge

Observations indicate that cell boundary effects may have influenced the stress results, especially in the first loading stage, probably due to poor interaction between EPS and the steel casings for the earth pressure cells.

Long term measurements from 3 earth pressure cells below the fill and one situated 2 m higher up have been plotted in fig. 16. During the first year of operation a stress decrease of 15 - 30 % was observed. Later only small variations with time have been observed. Measured stresses corresponds well with the theoretical vertical load in the lower part of the EPS fill.

In the upper part of the fill (with a higher material strength) lower stress than expected has been measured in a zone under the central part of the embankment. One explanation could be some kind of arching effect due to large subsoil settlements in the middle of the embankment. This can clearly be seen in fig.15 where the measurements from the settlement tube are shown. In the lower part of the fill it is difficult to explain load concentration and deformation in

the lowest EPS layer and likewise the low stress values in the upper part of the EPS fill. It may therefore be concluded that there still may be load distribution mechanisms in EPS fills that are not fully understood.

Another test was performed to check the stress result. A dumper with a weight of 33 tons was placed at different distances from the abutment. In the case when it was placed directly upon the abutment an increase of 6 kPa was

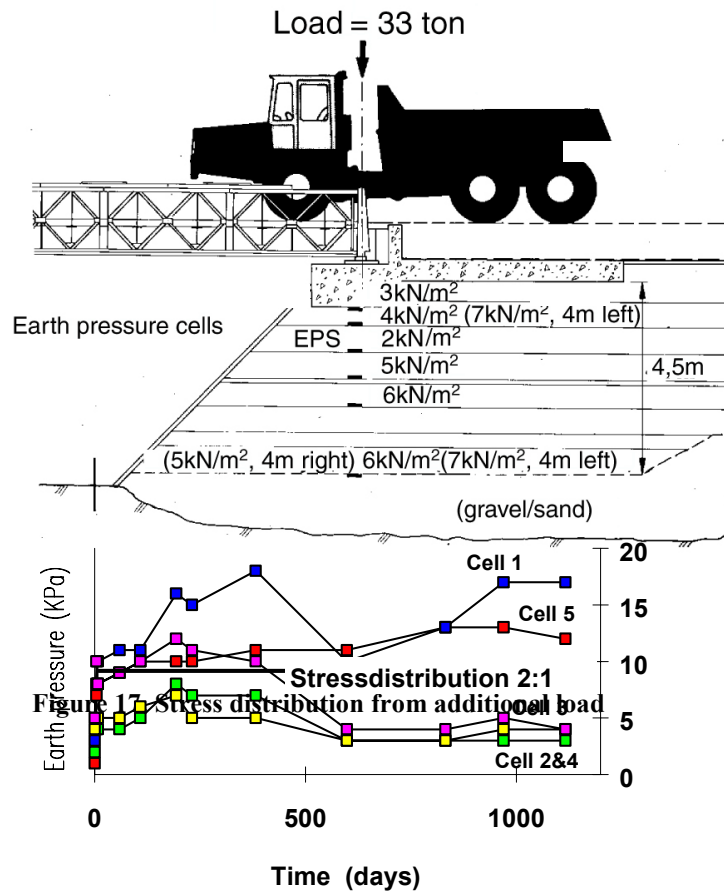

Figure 17. Stress distribution from additional load

expected. The measured stress increases in the various fill levels with the additional load from the dumper correspond well with the stress distribution without the dumper. The increase in stress levels from the dumper is shown in fig.17. The same tendency to reduced vertical pressure in a zone beneath the abutment was also observed here. After unloading the abutment, the pressure cells immediately returned to the initial stress levels.

Attempts have been made to evaluate the stress distribution in EPS blocks based on stress observations from the test hall experiments and stress observations at the Løkkeberg bridge. Stresses between blocks are of course difficult to measure and the results obtained vary quite a bit. In general measured stresses are, however, relatively low and indicate that the outer perimeter of the stress bulb may lie within a slope with a gradient 2:1 measured from the outer edge of the loading area. However, depending on the stiffness of the loading area and possible load eccentricities, local stress concentrations may occur. In figure 18 the stress level at the bottom of the fill with distribution gradient 2:1 is indicated with a black line and may be compared to the stress levels of cells 2, 3, 4 and 5.

REPAIR OF HJELMUNGEN BRIDGE

Hjelmungen bridge is a three span, 54 m long continuous concrete deck bridge completed in 1992 with abutments and pillars founded on concrete piles to firm ground. The 5 m high fills adjoining the bridge consisted partly of ordinary filling materials partly of waste material from the production of Leca building blocks. The fills rested on subsoil consisting of some 10 – 14 m of soft sensitive marine clay, partly quick and with a high water content.

Some 2 years after completion it became evident that the bearing capacity of the soil beneath the abutments had been exceeded as excessive settlements occurred and the abutments inflicted damage to the bridge deck. Deformation monitoring was initiated and it soon became clear that immediate repair measures had to be initiated. Since settlement caused by the approach fills was the main problem, it was decided to reduce the load on the subsoil by some 30 – 40 kN/m² in order to re-establish the initial subsoil stress conditions. This involved replacing parts of

the fills with EPS blocks and supporting new bridge abutments directly on the EPS. The repair design is indicated in figure 19.

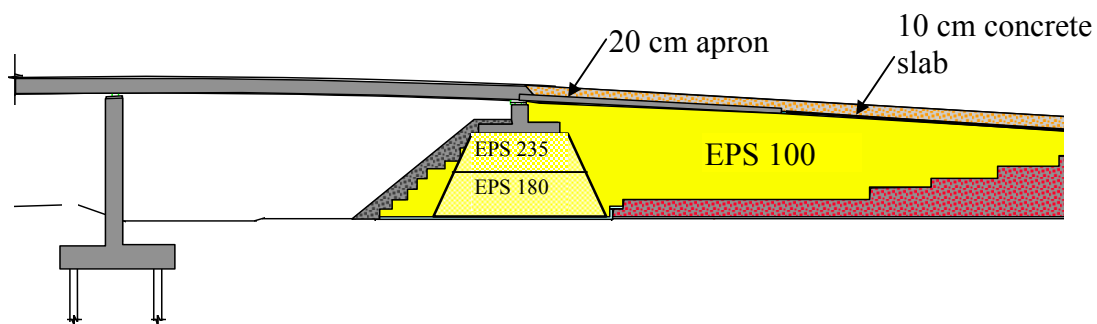

Figure 19. Supporting bridge abutments directly on EPS, Hjelmungen bridge, Norway

Repair works were initiated in December 1995 and completed in the spring of 1996. One abutment was treated at a time while the bridge deck was provided with a temporary support as shown in figure 20. Thickness and densities of the original filling materials were recorded as they were removed in order to have accurate data for control of load and settlement calculations. After removing the old abutments, the concrete piles were inspected regarding possible damage before being cut at ground level. No pile damage was observed. Construction of the EPS fills could then start. In this case three different qualities of EPS were utilized. In the zone directly beneath the bridge abutment, as indicated by the trapezoidal shaped lines in figure 19, a material quality of $\sigma = 235$ kPa was specified for the first three block layers beneath the bottom slab of the abutment. Further down a material quality of $\sigma = 180$ kPa was



Figure 20. Temporary support of abutments at Hjelmungen

specified within the indicated zone. For the rest of the EPS fill a material quality of $\sigma = 100$ kPa was used. These quality requirements have been decided based on evaluation of stress distribution in the material in order to keep the stress level for dead loads within 30 % of the material strength. Stricter geometric requirements than normal were also enforced related to block dimensions in order to obtain an even fill and reduce initial deformations when the load from the bridge deck was transferred to the new abutment.

Behind both abutments a 10 m long and 200 mm thick concrete apron was specified to be cast above the EPS fill as a friction plate in order to take up horizontal forces on the abutment. On the rest of the EPS fill a concrete slab of 100

mm thickness was specified. To complete the road pavement 400 mm of pavement material was placed on top of the concrete slab.

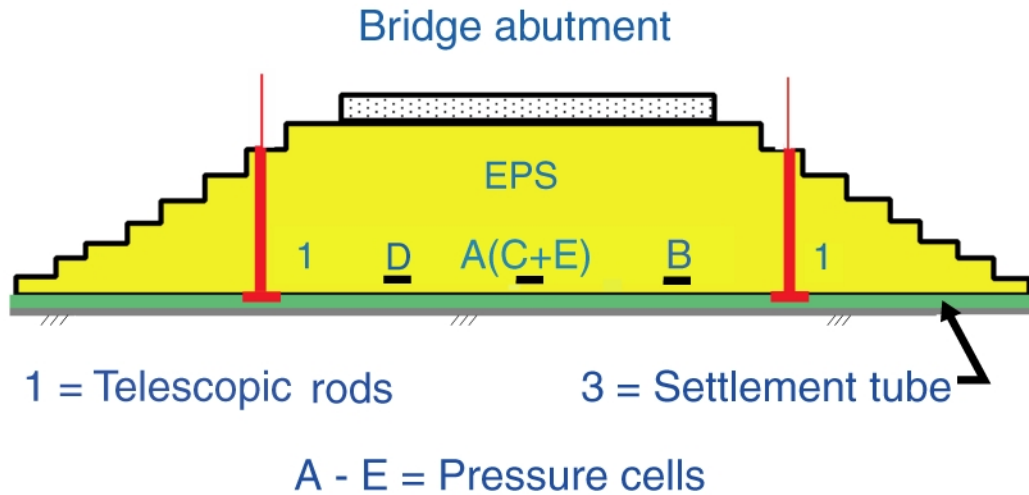

Figure 21. Cross section indicating location of monitoring equipment

In order to monitor the behaviour of the reconstructed bridge both settlement and stress gauges have been installed. The different types of gauges and their locations in relation to the bridge abutment are indicated on the cross section in figure 21. Prior to reconstruction the settlement rates of the adjoining fills were observed to be 100 mm/year and constant. After reconstruction the settlements have nearly been halted as shown on figure 22.

Observed stresses beneath the EPS fill indicate a higher stress under the central part of the abutment than under the edges as shown in figure 23. Calculated loads on the abutment are indicated by the heavy line drawn in the diagram. Problems associated with providing enough lifting force when jacking up the bridge deck may, however, indicate that reaction forces from the bridge deck are somewhat higher than calculated.

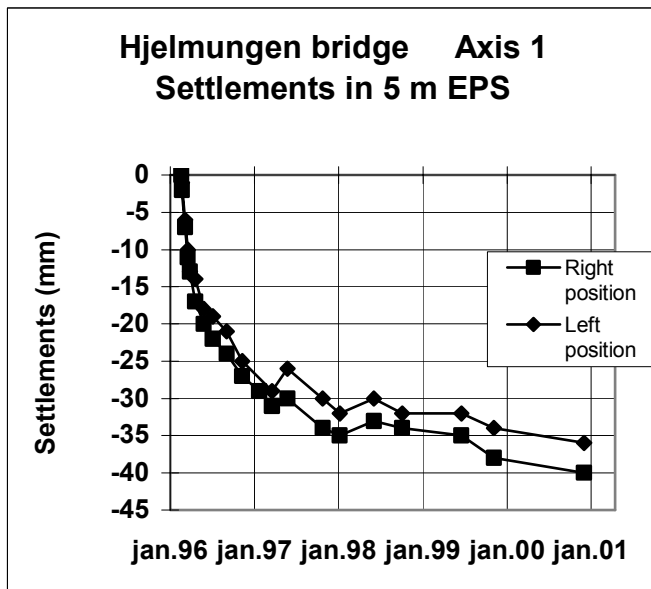

Figure 22. Measured settlements at Hjelmungen

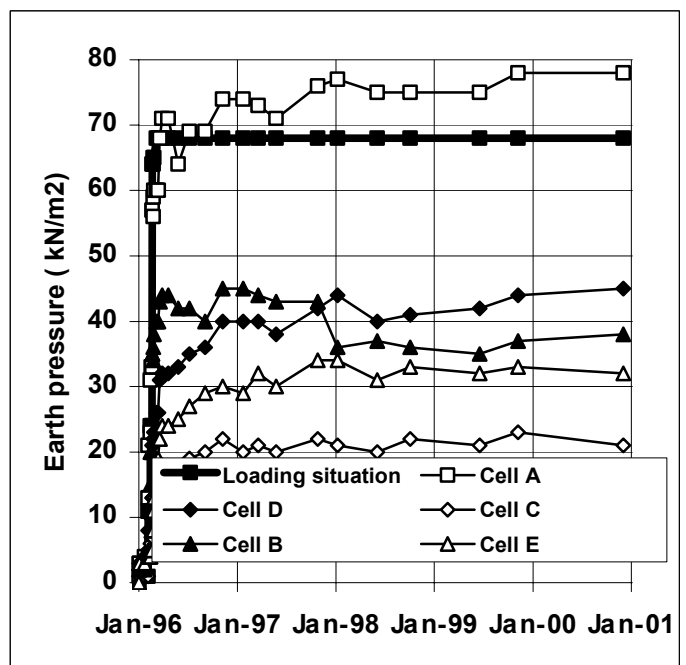

Figure 23. Earth pressure below EPS layer at Hjelmungen

DURABILITY

Although polystyrene is a stable chemical compound it may dissolve when exposed to petrol agents. When placed in a road fill the EPS blocks are therefore protected either by a concrete slab on top of the blocks also serving as a load distributing layer, or a high density polypropylene sheet. Although it is possible that a petrol tanker may overturn and spill petrol on the road surface at the location of an EPS fill, the statistical likelihood that such an event should occur is very small and the precautions mentioned above should be sufficient to protect the EPS. Also it will take some time for the petrol fluid to percolate through the soil on the side slopes, allowing time for corrective measures. Still, if a petrol spill should find its way to the EPS, only the outer blocks are likely to be effected and repair should be easy to perform. During the nearly 30 years that have passed since the first EPS fill was placed and the accelerated use of the EPS method on a worldwide scale in later years, no such spill incident has been reported.

FAILURES

Of the many EPS projects now completed in many parts of the world, only five known failures have been reported. Two failures are associated with water fluctuations and buoyancy forces. The other three are caused by fires.

On the 16th of October 1987 Northern Europe experienced exceptionally strong storms with high wind velocities and high rainfall intensities. Norway was also exposed to major floods, and in the Oslo area the first EPS fill built in 1972 floated off as did an adjacent section of motorway constructed some years later. What was wrong? Had the dangers of buoyancy forces not been considered? Yes, such calculations had been performed, but the highest possible flood level predicted at the design stage in 1972 was 0,85 m lower than the flood level that occurred in October 1987. So it was rainfall and flood level predictions in 1972 that were misleading.

Also the second failure reported from Thailand involved an unexpected high water level causing a completed road fill to be washed away. So it should be duly noted that the dangers of buoyancy forces should be carefully studied when considering the design of an EPS fill. Often soft subsoils are located in lowland areas subjected to flooding. In such cases accurate predictions of the highest possible water level are essential in order to obtain a safe and lasting road structure.

Ordinary polystyrene is a combustible material and will burn when set on fire. For this reason some precautions should be taken when constructing EPS fills using normal quality material. Such precautions may include fencing in any stockpiles at the construction site and provide guards round the clock, or place the blocks directly in the fill when they arrive on site, working round the clock if necessary. Alternatively a self-extinguishing quality of EPS may be used at approximately 5 % increase in production costs. However, once the EPS is covered by the pavement material on top, and soil on the slopes, there will not be sufficient oxygen available to sustain a fire.

Two failures due to fires have occurred in Norway, and both were caused by welding activities on bridge abutments adjacent to EPS fills, during the construction phase. In the first case 1500 m³ of EPS were transformed into black smoke in a matter of some 10 minutes. The concrete bridge abutment was also damaged due to the heat developed with concrete spalling from the reinforcing bars. Since the fire was initiated by sparks from welding activities on the bridge, the contractor responsible for the welding had both to repair the bridge abutment and replace the EPS fill at his own expense. A similar incident occurred in 1995 and again the repair costs had to be covered by the contractor responsible for the welding activities. So the fire potential should not be overlooked and in some counties in Norway the local highway offices are only using self-extinguishing material at a somewhat higher cost in order to exclude fire hazards.

A third fire incident is reported from Japan.

CONCLUSIONS

From the observations discussed above it may be fair to conclude that no deficiency effects are to be expected from EPS fills placed in the ground for a normal life cycle of 100 years. This should hold true provided possible buoyancy forces resulting from fluctuating water levels are properly accounted for, the blocks are properly protected from accidental spills of dissolving agents and the applied stress level from dead loads is kept below 30-50 % of the material strength. The observed performance of the many projects designed and constructed on these principles around the world so far supports this conclusion.

REFERENCES

Frydenlund T. E , Aabøe R. Expanded Polystyrene The Light Solution. International symposium on EPS construction method. Tokyo 1996.

Aabøe, R. Deformasjonsegenskaper og spenningsforhold i fyllinger av EPS (Deformation characteristics and stress conditions in fills of EPS) Internrapport 1645. Public Road adm. 1993.

Skuggedal H, Aabøe R. Temporary overpass bridge founded on expanded polystyrene. Proceedings XECSMFE, Florence May 1991, Volume 2.

Magnan & Serratrice, Propriete mecanique du polystyrene expanse pour ses application en remblais routier. Bulletin ICPC , France, 1989.